

CONSENT AND APPROVAL OF THIS DRAWING IS CONDITIONAL UPON THE CONTRACTOR'S OBLIGATION TO OBTAIN ALL NECESSARY PERMITS AND APPROVALS FROM THE RELEVANT AUTHORITIES. THE CONTRACTOR SHALL BE RESPONSIBLE FOR OBTAINING ALL NECESSARY PERMITS AND APPROVALS. THE CONTRACTOR SHALL BE RESPONSIBLE FOR OBTAINING ALL NECESSARY PERMITS AND APPROVALS. THE CONTRACTOR SHALL BE RESPONSIBLE FOR OBTAINING ALL NECESSARY PERMITS AND APPROVALS.

- NOTES**
1. THIS DRAWING IS TO BE READ IN CONJUNCTION WITH THE SPECIFICATIONS AND ALL RELEVANT ARCHITECTS AND SERVICES ENGINEERS DRAWINGS.
 2. DO NOT SCALE. USE FIGURED DIMENSIONS ONLY.
 3. DRAWINGS SHALL BE CHECKED BY CONTRACTOR AND ANY DISCREPANCIES (DIMENSIONS) SHALL BE BROUGHT TO THE ATTENTION OF THE ENGINEER BEFORE WORK IS COMMENCED.

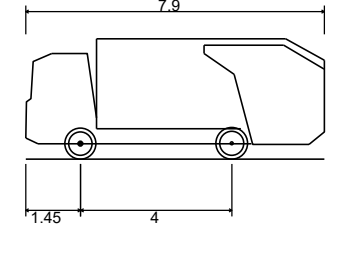

DB32 Refuse Vehicle	7.900m
Overall Length	2.400m
Overall Width	3.183m
Min Body Ground Clearance	0.388m
Max Track Width	2.400m
Lock-to-lock time	6.10s
Curb to Curb Turning Radius	9.625m

REV	DATE	DESCRIPTION	DRG	APP

CLIENT: BALLYMOUNT PROPERTIES LTD.

ARCHITECT: PRO ARCHITECTS
59 NORTHUMBERLAND ROAD
DUBLIN 4

GARLAND
DUBLIN LIMERICK WATERFORD INTERNATIONAL
T: +353 1 4846422 F: +353 81 319708 T: +353 81 818111 T: +353 81 319708
E: info@garlandconsultancy.com W: www.garlandconsultancy.com

PROJECT: RESIDENTIAL AND NEIGHBOURHOOD CENTRE DEVELOPMENT (PHASE 1) AT FORMER MAGEE BARRACKS

TITLE: VEHICLE TRACKING LAYOUT REFUSE VEHICLE

STATUS: **PLANNING APPLICATION**

DRAWN: JC	DES. BY: BM
CHK. BY: BM	APP. BY: CR
DATE: 07/06/19	JOB No:
AS SCALE: 1:2000	R1831